

Silensor® SLS "SUPER-QUIET" POOL PUMPS

SILENSOR



Davey's all new water-silenced pool pumps offer super quiet operation with high efficiency, making them the ideal choice for modern swimming pools.

FEATURES & BENEFITS

Super-Quiet - Silensor's water-cooled motor uses a small water flow around the stainless steel, corrosion proof motor shell which captures noise and vibrations allowing the Silensor's super-quiet operation (typically below 56dBa).

Cost Saving - Silensor is designed using the latest computational fluid dynamics to move water up to 15% more efficiently than most standard pool pumps. Quietness may allow operation of the pumps late at night when energy costs are much lower (off peak).

Long Lasting - Silensor's advanced design utilises high performance UV stabilised polymers for outdoor installation. Bolts, screws and highly corrodible metals that can rust and render a pump unserviceable have also been replaced with easily operated clamp rings, ensuring simple maintenance, year after year.

Dependable - Silensor features a 'Floating Neckring' system for protecting the vital mechanical seal within the pump. This system will reduce wear by excluding debris, extending service life and reducing maintenance. Automatic 'Dry Run' protection will stop the pump running when it has no water moving inside the pump which is the major cause of premature pump failure.

Performance - Silensor features a patented clamped impeller design providing superior air and water handling ability. The design also aids priming of the pump, improving the options for positioning the pump in more versatile locations.

Convenient - SLS models are an ideal replacement for Davey PACR & PA models.

DEPEND ON
DAVEY

WATER PRODUCTS

DESIGNED & MADE IN AUSTRALIA 3yr FULL GUARANTEE

Silensor® SLS "SUPER-QUIET" POOL PUMPS

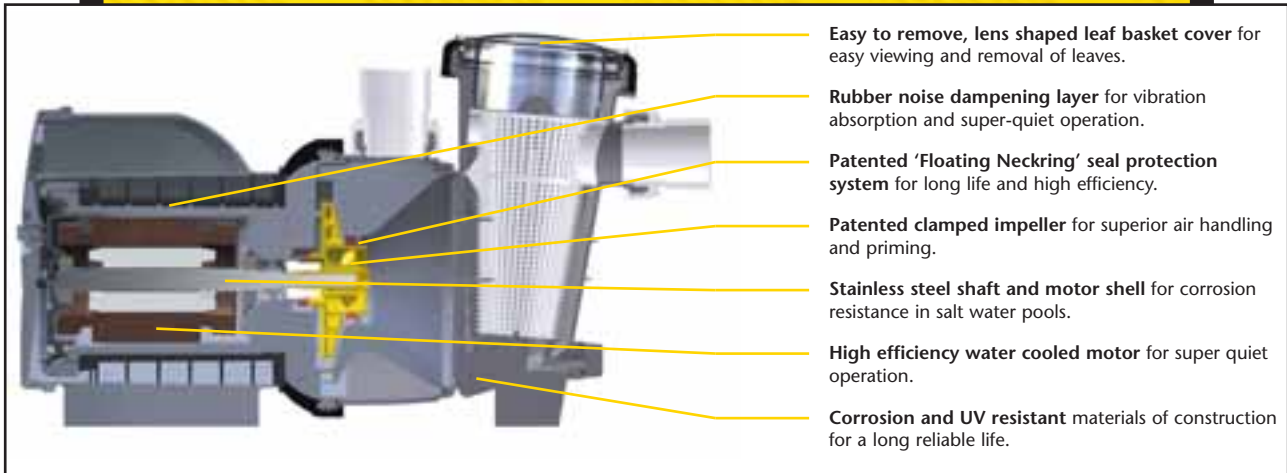

ELECTRICAL DATA

Model No.	SLS 100	SLS 150	SLS 200	SLS 300
Voltage (V)	220-250			
Supply Frequency	50Hz			
Start Current (A)	18	18	18	20
Run Current (A)	3.6	4.0	4.9	5.9
Motor Input Power (W)	740	860	1090	1400
Motor Output Power (W)	525	620	775	960
RPM	2850			
Enclosure Class (IP)	56			
Insulation Class	F			
Approval No.	V06258			

OPERATING LIMITS

Model No.	SLS 100	SLS 150	SLS 200	SLS 300
Water Temperature	Max 50°C			
Ambient Temperature	Max 55°C			
dBa @ 1 metre	56	55	54	54

MODEL NUMBER IDENTIFICATION

SLS	300
SLS = Silensor Small (PACR Replacement)	300 = 300lpm in a typical installation.

MODEL	Mounting Holes Dia.	Inlet P.V.C. (mm)	Outlet P.V.C. (mm)	Net Weight (kg)
SLS 100	10mm x 34mm deep	40/50	40/50	11.0
SLS 150		40/50	40/50	11.0
SLS 200		40/50	40/50	11.5
SLS 300		40/50	40/50	11.5

All dimensions in mm unless otherwise stated.

HYDRAULIC PERFORMANCE

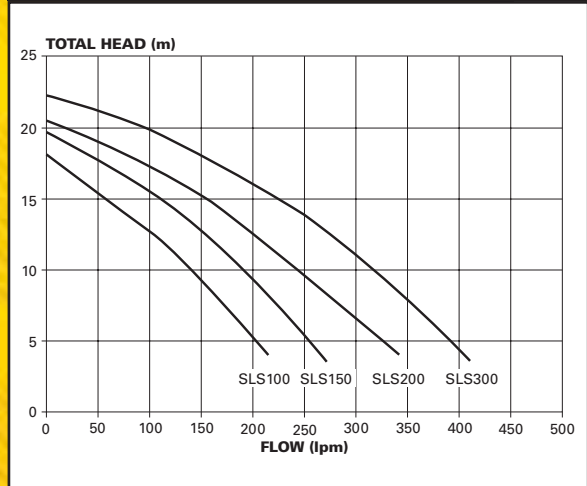

DIMENSIONS

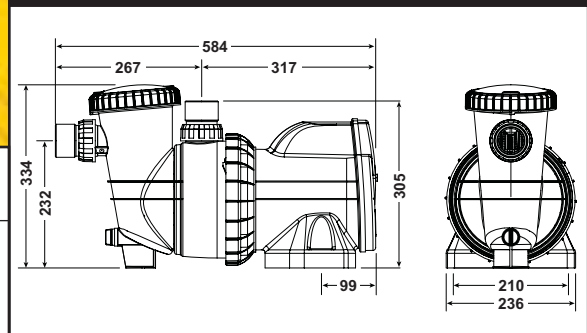

DEPEND ON
DAVEY

WATER PRODUCTS



Visit Davey on-line for further information
davey.com.au

All details in this leaflet are accurate at time of printing. This literature is not a complete guide to product usage. Further information is available from your Davey dealer, Davey Customer Service Centre and from the relevant product Installation & Operating Instructions. This datasheet must be read in conjunction with the relevant product Installation & Operating Instructions and all applicable statutory requirements. Product specifications may change without notice. © Davey and Silensor are registered trademarks of Davey Water Products Pty Ltd. © Davey Water Products Pty Ltd 2006.

Davey Water Products Pty Ltd

Member of the GUD Group
ABN 18 066 327 517
Head Office and Manufacturing
6 Lakeview Drive, Scoresby, Australia 3179
Ph: +61 3 9730 9222
Fax: +61 3 9753 4100
Website: davey.com.au
Customer Service Centre
Ph: 1300 2 DAVEY
Fax: 1300 304 850
E-mail: sales@davey.com.au
Interstate Offices
Sydney • Brisbane • Adelaide • Perth • Townsville

International

6 Lakeview Drive,
Scoresby, Australia 3179
Ph: +61 3 9730 9121
E-mail: export@davey.com.au

New Zealand

7 Rockridge Avenue,
Penrose, Auckland 1330
Ph: +64 9 570 9135
Website: daveynz.co.nz
E-mail: sales@daveynz.co.nz

Germany

Kantstrasse 53,
04275 Leipzig
Ph: +49 341 301 0412
E-mail: akrenz@daveyeurope.com

USA - Davey Pumps Inc.

1005 N. Commons Drive,
Aurora, Illinois 60504
Ph: +1 630 898 6976
Website: daveyusa.com
E-mail: sales@daveyusa.com